



POWERMAX 600 REFRIGERANT RECOVERY SYSTEM

www.thermaflo.cc

OPERATIONS MANUAL

VERSION 2.0

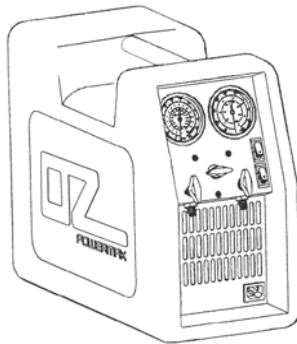

ELECTRICAL SCHEMATIC

I.T.S. Thermaflo would like to thank you for selecting the OZ-PowerMax Recovery System. Your PowerMax recovery unit, like all THERMAFLO products, has gone through extensive testing to assure the highest degree of quality. THERMAFLO backs up this claim of quality with a comprehensive service program and a full warranty. The people at THERMAFLO have put a great deal of time, effort and pride in producing this product. We believe that our continued diligence will insure better products, services and satisfied customers.

Thanks again for your confidence in THERMAFLO!

THERMAFLO a division of Industrial Tool Solutions

Customer Service # 800-848-4232 M-F 9am to 5pm EST.

Fax # (413) 733-9267

SAFETY CONSIDERATION

PRESSURIZED containers or overfilled containers may cause violent explosions and possible injury or death. Use only D.O.T. approved refillable refrigerant containers. Federal regulations require refrigerants to be transported in containers meeting D.O.T. specs 4BW or 4BA.

HOSES may contain refrigerant under pressure. Contact with refrigerant may cause injury. Wear protective equipment. Disconnect hoses with extreme caution.

HIGH VOLTAGE electricity is present inside cabinet. Disconnect power before servicing.

USE only with refrigerants 12, 22, 500, 502, 134a 410a and blends with similar pressures.

THIS equipment is for use by qualified and trained personnel only. Operators must be familiar with refrigerants and the dangers of pressurized containers.

HELPFUL HINTS

- Always close inlet (V1) before closing discharge (V3).
- If unit starts to “chug”, throttle down inlet (V1).
- If discharge pressure starts to rise, subcool the recovery tank.
- Never turn the recover/self-evac (V2) while unit is running.
- Always purge your hoses and recovery tank of non-condensables.
- Always use an inlet filter (part # ALF-032).
- Always weigh your recovery tank with a scale while using the test plug.
- Maintain an inlet pressure below 90 psig. during long-term vapor recovery.
- While subcooling, maintain 100-200 psi higher discharge pressure than the recovery tank’s pressure.

STANDARD RECOVERY

SET UP

1. CONNECT POWER CORD AND SAFETY CABLE OR TEST PLUG.
2. CONNECT CENTER HOSE OF MANIFOLD TO INLET FILTER.
3. CONNECT HOSE ON DISCHARGE PORT TO LIQUID PORT ON TANK.
4. CLOSE INLET VALVE (V1).
5. TURN CONTROL VALVE (V2) TO RECOVER POSITION.
6. OPEN DISCHARGE VALVE (V3).
7. OPEN HIGH SIDE OF SERVICE MANIFOLD.
8. OPEN LIQUID SIDE OF RECOVERY TANK.

OPERATION

1. TURN POWER ON AND PRESS START BUTTON.
2. **SLOWLY** OPEN INLET PORT (V1).
3. ONCE LIQUID IS RECOVERED OPEN LOW SIDE OF MANIFOLD.

SHUT DOWN

1. CLOSE INLET VALVE (V1) ONCE DESIRED VACUUM IS ACHIEVED.
2. CLOSE LIQUID VALVE ON RECOVERY TANK.
3. CLOSE DISCHARGE VALVE (V3).
4. TURN POWER SWITCH OFF.

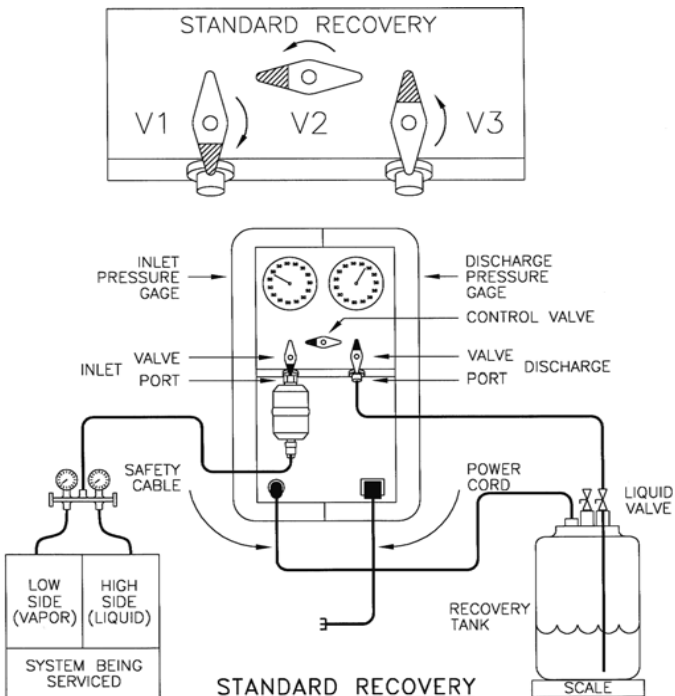

VAPOR RECOVERY

SETUP

1. CONNECT HOSES AS SHOWN BELOW.
2. CLOSE INLET VALVE (V1).
3. TURN CONTROL VALVE (V2) TO RECOVER POSITION.
4. OPEN DISCHARGE VALVE (V3).
5. OPEN LIQUID VALVE ON THE RECOVERY TANK.

OPERATION

1. TURN POWER ON AND PRESS START BUTTON.
2. **SLOWLY** OPEN INLET VALVE (V1).

SHUT DOWN

1. CLOSE INLET VALVE (V1) ONCE DESIRED VACUUM IS ACHIEVED.
2. CLOSE LIQUID VALVE ON RECOVERY TANK.
3. CLOSE DISCHARGE VALVE (V3).
4. TURN POWER SWITCH OFF.

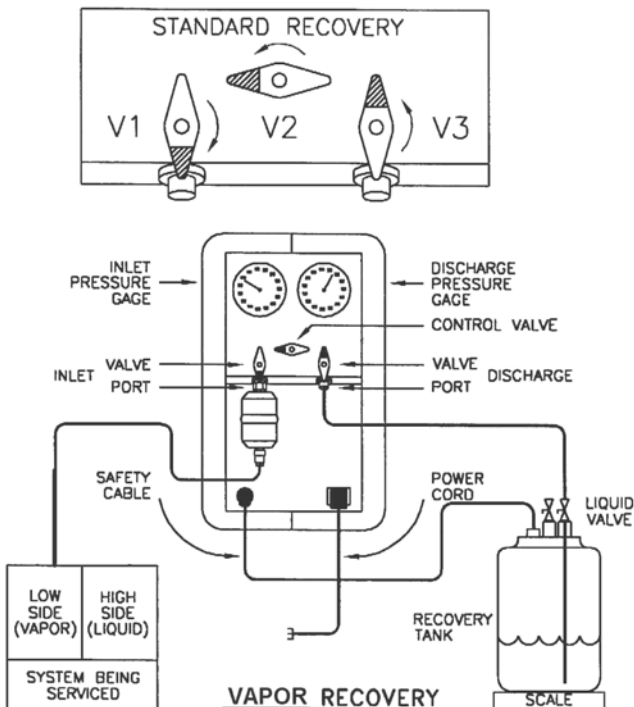

PUSH / PULL RECOVERY

(LIQUID RECOVERY FOR 20 LBS. OR MORE)

SET-UP

1. CONNECT HOSES AS SHOWN BELOW.
2. CLOSE INLET VALVE (V1).
3. TURN CONTROL VALVE (V2) TO RECOVER POSTION.
4. OPEN DISCHARGE VALVE (V3).
5. OPEN LIQUID & VAPOR VALVES ON THE RECOVERY TANK.

OPERATION

1. TURN POWER ON AND PRESS START BUTTON.
2. **SLOWLY** OPEN INLET VALVE (V1).
3. ONCE ALL LIQUID HAS BEEN RECOVERED, GO TO VAPOR RECOVERY (FIG 2).

SHUT DOWN

1. CLOSE INLET VALVE (V1) ONCE DESIRED VACUUM IS ACHEIVED.
2. CLOSE LIQUID VALVE ON RECOVERY TANK.
3. CLOSE DISCHARGE VALVE (V3).
4. TURN POWER SWITCH OFF.

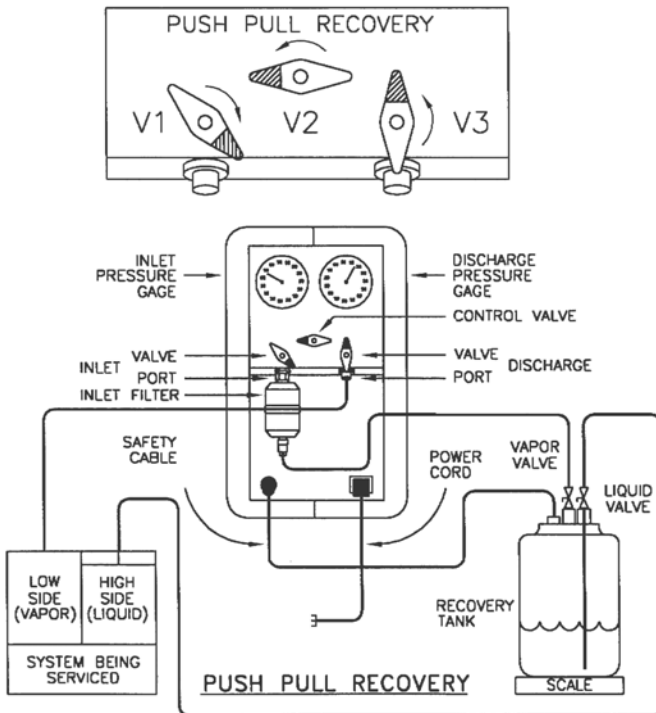

TANK TO TANK TRANSFER

SET-UP

1. CONNECT HOSES AS SHOWN BELOW.
2. CLOSE INLET VALVE (V1).
3. TURN CONTROL VALVE (V2) TO RECOVER POSITION.
4. OPEN DISCHARGE VALVE (V3).
5. OPEN LIQUID VALVE ON THE RECOVERY TANK (A).
6. OPEN LIQUID VALVE ON THE RECOVERY TANK (B).

OPERATION

1. TURN POWER ON AND PRESS START BUTTON.
2. **SLOWLY** OPEN INLET VALVE (V1).

SHUT DOWN

1. CLOSE INLET VALVE (V1) ONCE DESIRED VACUUM IS ACHIEVED.
2. CLOSE BOTH LIQUID VALVES ON EACH RECOVERY TANK.
3. CLOSE DISCHARGE VALVE (V3).
4. TURN POWER SWITCH OFF.

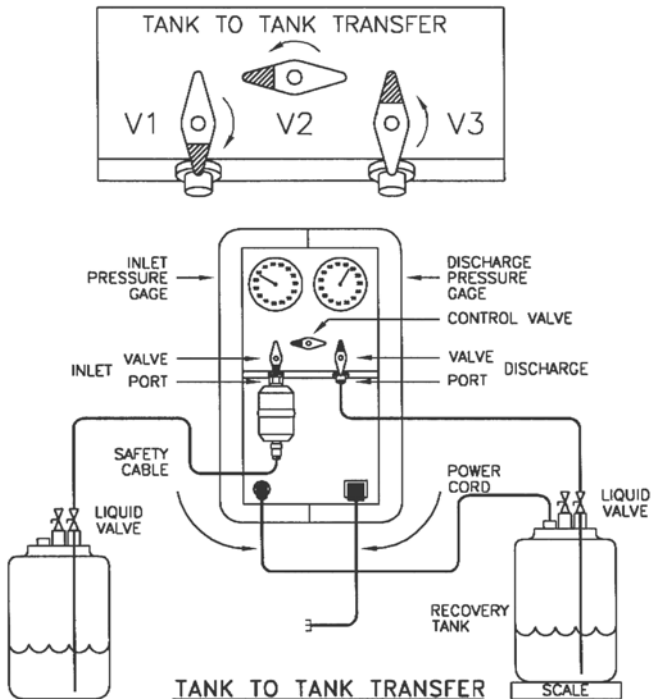

(A) FULL TANK

(B) EMPTY TANK

SELF EVACUATION

SET UP

1. CONNECT HOSES AS SHOWN BELOW.
2. CLOSE INLET VALVE (V1).
3. TURN CONTROL VALVE (V2) TO SELF-EVAC POSITION.
4. OPEN DISCHARGE VALVE (V3).
5. OPEN LIQUID VALVE ON THE RECOVERY TANK.

OPERATION

1. TURN POWER ON AND PRESS START BUTTON.
2. SUCTION GAUGE WILL THEN GO INTO A VACUUM.
3. SELF-EVACUATION PROCESS IS COMPLETED.

SHUT DOWN

1. CLOSE LIQUID VALVE ON RECOVERY TANK.
2. CLOSE DISCHARGE VALVE (V3).
3. TURN POWER SWITCH OFF.

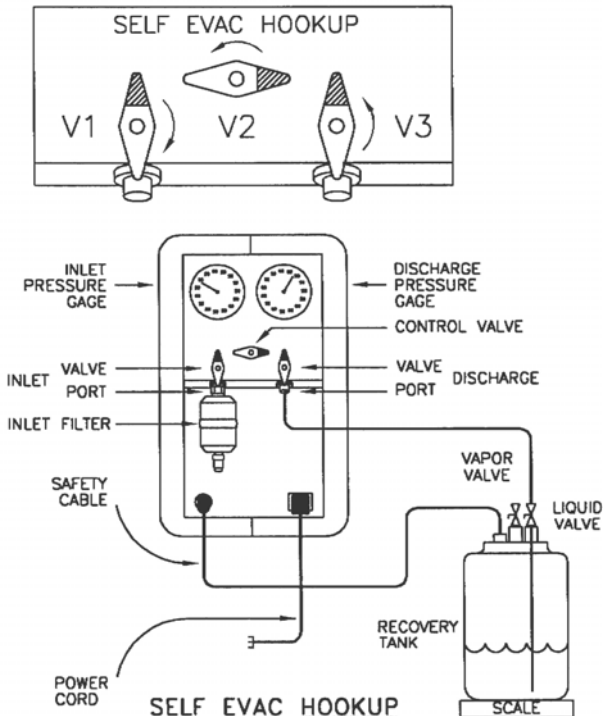

QUICK TEST

With no hose connected, unit plugged in and test plug connected:

1. OPEN both Inlet Valve (V1) and Discharge Valve (V3).
2. PLACE Control Valve (V2) in RECOVER position.
3. Start unit.

*Unit **SHOULD** be sucking on inlet port.*

4. CLOSE Inlet Valve (V1).

*Suction Gauge **SHOULD** go into 25" vacuum.*

5. OPEN Inlet Valve (V1).

6. CLOSE Discharge Valve (V3).

*Discharge Gauge **SHOULD** build to 150 psig in 30 seconds.*

Technical Support

800-848-4232

Mon-Fri 9am to 5pm EST.

TROUBLESHOOTING

SYMPTOM	CAUSE	CURE
Unit does not start.	No power at plug. Circuit breaker is open. Safety cable not connected. Test plug not connected.	Check voltage on plug. Reset circuit breaker. Connect both ends. Connect test plug.
Unit starts then shuts off	Discharge valve is closed. Tank valve closed. Too much liquid coming in.	Open discharge valve. Open valve on tank. Partially close inlet valve.
Unit leaks refrigerant.	Blown head gaskets. Loose flare connection. Cracked plumbing.	Replace head gaskets. Tighten all connections Replace plumbing section.
Unit recovers slowly.	Tank pressure is too high. Inlet filter is clogged.	Sub-Cool recovery tank. Change the filter.
Unit shuts off during Sub-Cool.	Tank pressure too high.	Partially close inlet valve.

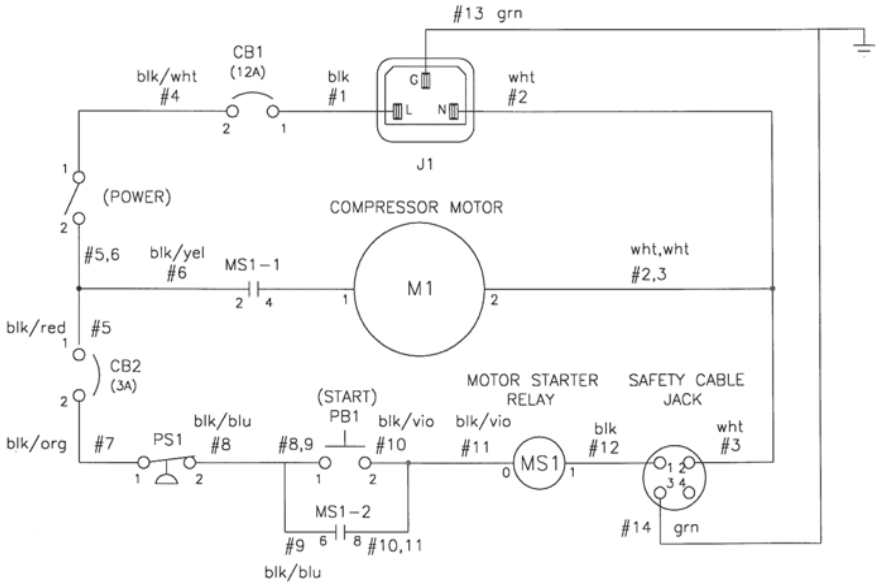

(2) YEAR LIMITED WARRANTY

I.T.S. Thermaflo promises to the owner to repair or, at Thermaflo's option, to replace any part of the PowerMax which proves to be defective in workmanship or material under normal use for a period of two (2) years from date of sale. During this period, Thermaflo will provide all parts and labor necessary to correct such defects, free of charge.

- EXCLUSIONS:
- 1) Motor: The compressor motor has a (1) year unlimited warranty.
 - 2) Filtering: If during the warranty evaluation it is determined that an external filter was not used during the operation of the unit, Thermaflo reserves the right to void the warranty.

In no event will Thermaflo be liable for incidental or consequential damages, or for damages resulting from external causes such as abuse, misuse, incorrect voltages or acts of God. This warranty does not cover service calls which do not involve defective workmanship or materials. This warranty gives you specific rights, and may also have other rights which vary by state.

FOR WARRANTY / NON-WARRANTY REPAIR SERVICE:

- 1) Call (800) 848-4232 Thermaflo Customer Service. Have model and serial number ready.
- 2) Thermaflo will then issue a Return Authorization Number (R.A.#) for the repair.
ALL RETURNS MUST HAVE AN R.A. NUMBER PRIOR TO SHIPPING.
- 3) Ship the product prepaid to:

I.T.S. Thermaflo Repair Dept.
409 Lake Ave.
Bristol, CT 06010

8

Dear Customer: